

**INSTALLATION REQUIREMENTS FOR WOOD / CHAIN LINK FENCES**  
 (FBC-B §2328 and §2224)

**Footings:** to be performed after all the posts holes are completed in accordance to the approved plans and Florida Building Code, Broward County Administrative Provisions §110.3.A.2.

**Final Inspection:** to be made after installation and completion of all elements of construction. The following items will be observed at final inspection:

- Wood fences shall be constructed of decay and termite-resistant material as specified in § 2304.12 of the Florida Building Code, Building.
- Wood fences shall be designed according to the loads as specified in §1616.2.1 and § 2328 of the Florida Building Code, Building.
- Wood fences not exceeding six (6) feet in height may be constructed to meet the following minimum requirements:
  1. Vertical post of nominal 4 x 4 to be spaced according to height of fence. (See detail below).
  2. Post shall be embedded 2'-0" into a concrete footing 10" in diameter and 2'0" deep, § 2328.2.
  3. Horizontal framing shall consist of a minimum of 3 horizontal rails of nominal 2 x 4 material and shall be fastened according to § 2324.3 of the Florida building code; fences 4' or less will only require 2 horizontal rails.
  4. All fasteners shall be corrosion resistant as per § 2324.2 of the Florida building code.

**Zoning Requirement:** all wooden fences shall have the recognizable finished side facing adjacent properties and right-of-ways (see zoning requirements for the proposed fence).

**WARNING:** Pre-manufactured sections may not comply with this code. Product approval may be required.



Board on Board



Shadowbox



Stockade

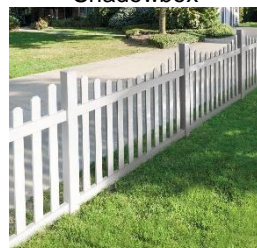

Picket

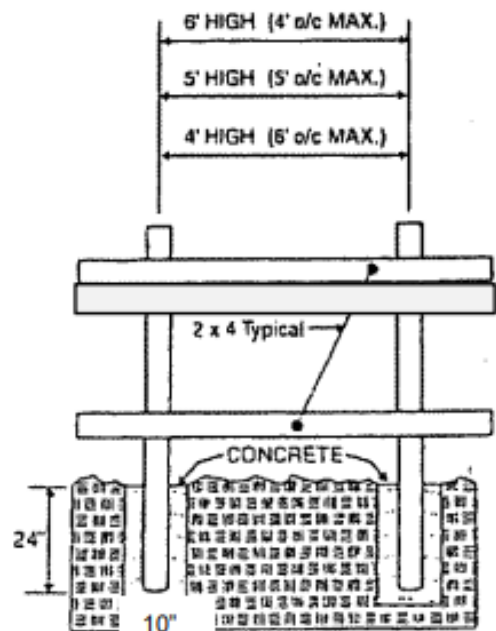

## §2224 - High Velocity Hurricane Zones – Chain Link Fences

**§2224.1** Chain Link Fences in excess of 12 feet (3.7 m) in height shall be designed according to the loads specified in chapter 16 (High Velocity Hurricane Zones).

**§2224.2** Chain Link Fences less than 12 feet (3.7 m) in height shall be designed according to the loads specified in chapter 16 (High Velocity Hurricane Zones) of the FBC or may be constructed to meet the minimum requirements specified in FBC-B “Table 2224”.

### SECTION 2224 HIGH-VELOCITY HURRICANE ZONES – CHAIN LINK FENCES

**TABLE 2224  
CHAIN LINK FENCE MINIMUM REQUIREMENTS**

Fence Height (ft.)	Terminal Post Dimensions (o.d. x wall thickness) (in inches)	Line Post Dimensions (o.d. x wall thickness) (in inches)	Terminal Post Concrete Foundation Size (diameter. x depth) (in inches)	Line Post Concrete Foundation Size (diameter. x depth) (in inches)
Up to 4	2-3/8 X 0.042	1-5/8 x 0.047	10 x 24	8 x 24
Over 4 to 5	2-3/8 X 0.042	1-7/8 x 0.055	10 x 24	8 x 24
Over 5 to 6	2-3/8 X 0.042	1-7/8 x 0.065	10 x 24	8 x 24
Over 6 to 8	2-3/8 X 0.110	2-3/8 x 0.095	10 x 36	10 x 36
Over 8 to 10	2-7/8 X 0.110	2-3/8 x 0.130	12 x 40	12 x 40
Over 10 to 12	2-7/8 X 0.160	2-7/8 x 0.120	12 x 42	12 x 42

For SI: 1 Inch = 25.4mm.

**NOTES:**

1. This table is applicable only to fences with unrestricted airflow.
2. Fabric: 12-1/2 gage minimum.
3. Tension bands: use one less than the height of the fence in feet evenly spaced.
4. Fabric ties: must be minimum the same gage of the fabric.
5. Fabric tie spacing on the top rail: five ties between posts, evenly spaced.
6. Fabric tie spacing on line posts: one less than height of the fence in feet, evenly spaced.
7. Either top rail or top tension wire shall be used.
8. Braces must be used at terminal posts if top tension wire is used instead of top rail.
9. Post spacing: 10 foot (3 m) on center maximum.
10. Posts shall be embedded to within 6 inch (152 mm) from the bottom of the foundation.
11. In order to follow the contour of the land, the bottom of the fence may clear the contour of the ground by up to 5 inch (127 mm) without increasing table values to the next higher limit.

Other types of fences, (Aluminum, P.V.C., Chain link with restricted air flow, etc...) must be designed to meet the Florida Building Code (FBC).

**ANY METHOD OF CONSTRUCTION NOT SPECIFIED HEREIN MUST BE PERFORMED IN ACCORDANCE WITH PLANS PREPARED BY AN ARCHITECT OR ENGINEER OR AN AUTHORIZED PRODUCT APPROVAL NOTICE OF ACCEPTANCE.**